



ORIGINAL ARTICLE

Design and Development of a Two-Wheel Tractor Coupled Bund Plastering and Canal (*Kiwul-Ela*) Making Equipment

E.A.A. Sandaruwan, G.V.T.V. Weerasooriya* and A.J. Fernando

Department of Agricultural
Engineering and Soil Science,
Faculty of Agriculture,
Rajarata University of Sri
Lanka

Correspondence:

*gvtvw@agri.rjt.ac.lk

Abstract

Rice (*Oryza sativa* L.) is the staple food and major crop in Sri Lanka. Improving rice cropping practices and production systems are required to enable sustainability. Presently bund cleaning, plastering, and *kiwul-ela* construction are done manually and there is no proper mechanical solution. Thus, this study was aimed to design and develop an appropriate bund plastering and *kiwul-ela* making equipment as a rear attachment to a walking type two-wheel tractor. The main components of the equipment are bund cleaner, bund plaster, *kiwul-ela* maker, depth controller, and main frame. The field condition of the test land was measured, and the bulk density and moisture content were 1.14 gcm^{-3} and 14.81% respectively. The prototype showed significantly higher comparative performances; 93.93% of time saving and 64.4% of cost reduction over the manual method ($p < 0.05$). Further, it showed highly satisfactory field performances; such as 2.045 kmh^{-1} operational speed (second gear), $0.032 \pm 0.002 \text{ m}$ plastering thickness, and $0.21 \pm 0.02 \text{ m}$ height, $52.054 \times 10^{-3} \text{ hah}^{-1}$ theoretical field capacity and 63.6% field efficiency. Due to the higher performance of this bund cleaning, plastering and *kiwul-ela* making equipment, the equipment could be suggested over manual method for small scale paddy farmers. The efficiency of the bund plastering could be further increased by increasing plastering height of the moldboard.

Keywords: Bund cleaner, Bund plastering, *Kiwul-ela* making

LIST OF ABBREVIATIONS

°C	- degrees of Centigrade
cm	- centimeter
EMC	- Equilibrium Moisture Content
g	- gram
h	- hour
J	- Joule
kg	- kilograms
kJ	- kilo joule
km	- kilometer
kW	- kilowatt
LKR	- Sri Lankan Rupees
m	- meter
MC	- Moisture Content
min	- minute
MJ	- mega joule
mm	- millimeter
N	- North
E	- East
V	- volt
W	- watt
kWh	- kilowatt hour

1. Introduction

Sri Lanka has been an agricultural country and the country's agriculture mainly depends on rice production and responsible for 30.5% of employment in the country in 2005. (Vaidya et al. 2016). Rice had been an integral part of the Sri Lankan food culture from ancient times. The per capita consumption of rice estimated to be 107 kg. yr⁻¹ depending on the price of rice (DOA, 2010). Paddy cultivation is mostly performed by the rural population of Sri Lanka. Land extent for paddy cultivation was 892,945 ha and percentage was 27.7 of total cultivated land (DOA, 2010).

The land preparation for paddy cultivation is a difficult task to be performed before cultivating. Bund plastering is one such difficult task which local farmers had been practicing manually for centuries. Bund plastering is usually done in two steps at the beginning of each crop season. First, the bund should be cleared from weeds and grass during initial ploughing. During bund clearing, usually the weeds are removed, and the bunds are cut into an angle (Seleshi et al. 2009). Then the bund should be plastered with a layer of mud after the second ploughing (Vaidya, 2016). This mud would moderately consist of water therefore, the mud can successfully retain on the slanted surfaces of the bund (Seleshi et al. 2009).

Bund cleaning minimizes the effect of pest attack and reduce the mixing of weed seeds in harvesting operation. Plastering minimizes the seepage and develops the water holding capacity in the plot. Construction of canal (*kiwul-ela*)

removes the excess water from the plot. Proper bunds help to limit water losses by seepage and under bund flows. Bunds should be well compacted, and any rat holes should be plastered with mud (DOA, 2015).

The currently available bund plastering equipment needs four-wheel tractor as the power source and the plastering equipment are expensive. Also, lack of large rectangular paddy plots for cultivation is a drawback for use the current bund plastering equipment. Therefore, the objective of this research was to design and develop a two-wheel tractor coupled bund plastering and canal making equipment to improve the plastering conditions for uniform plastering and reducing seepage.

2. Materials and Methods

2.1 Location of Fabrication, Testing and Evaluation

Fabrication was done at the Engineering workshop of the Faculty of Agriculture, Rajarata University of Sri Lanka. Lowland (paddy field) of the faculty research farm was used to evaluate the performance of the equipment.

2.2 Designing Concept

The main factors considered through the designing process were; readily available power source, affordable technology, easy handling in the field and low labor requirement. The low cost and readily available materials were utilized to construct a low-cost equipment. The ability of doing repairs by a village workshop was considered. Optimum dimensions, coupling, adjustable depth was considered to construct a

simple equipment for easy handling. The rear attachments for bund clearing and plastering should consist of the following features, low cost, a very simple mechanism which any farmer could understand, efficient than the manual bund preparation process, easy to operate for the local farmers, durable adopted to the rough paddy field conditions, easily maintainable and spare parts available (DCS, 1991).

2.2.1 Selecting Power Source

Two-wheel tractors are the popular and widely used farm power source in Sri Lanka. The size and topography of lowland field which is used for bund plastering and canal (*kiwul-ela*) constructing equipment match the capacity of two-wheel tractor. Thus, the model Kubota K 75 two-wheel tractor (walking type) was used as the power source with the horsepower of seven.

2.2.2 Affordable Technology

The affordable technology was considered in fabricating the equipment with readily available materials for reasonable price. Then the maintenance cost and the time consumption for the maintenance of the equipment would be low.

2.3 Easiness of Operation

The different functional components were coupled to the equipment to increase the easiness of operation. The number of operators need to manipulation and the point of attach the equipment were considered. Alterations to overcome the practical difficulties also were considered.

2.4 Easy Repairing

The equipment was constructed by using readily available materials such as flat iron bar and metal sheets. Therefore, the problems of maintenance can be addressed locally. The materials were combined by permanent fastening welding and temporary by nut and bolts.

2.5 Main Components of the Equipment

This design is consisted with five main components. Those are a bund cleaner, bund plaster (modified moldboard Plough), canal (*kiwul-ela*) constructor, depth controller, and main frame.

2.5.1 Bund Cleaner

The bund cleaner was constructed to remove the weeds and develop the bund angle. Constructing material for bund cleaner was gauge 14 iron sheet. The bund cleaner was constructed as a sharp plate with an adjustable pre-determined angle. The flat iron sheet was used to contact with the bund cleaner and the thickness, width and height of the flat iron sheet was 3 mm, 340 mm and 350 mm respectively. The bund cleaner was attached to the main frame which was made by 22 mm box bar. Fig. 1 shows the bund cleaner with dimensions.

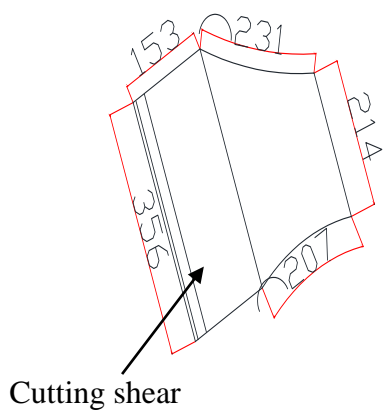

Figure 1: Bund Cleaner with Dimensions

2.5.2 Bund Plaster

Currently available moldboard plough was use as the initial model for the design development of bund plaster. Then it was modified by adding

the plastering plate which is a thin smooth plate (gauge 14) welded to the half of the modified moldboard plough. The bund plaster was easily detached from the main frame. The length and width of the plastering plate was determined according to the tractor dimensions; surface clearance and width of the tractor. The tractor clearance and width of the K-75 Kubota tractor were 2400 mm and 11000 mm, respectively. Therefore, the suitable length and width for the plastering plate were determined as 380 mm and 300 mm, respectively (Drawing 1). Fig. 2 shows the components of bund plaster.

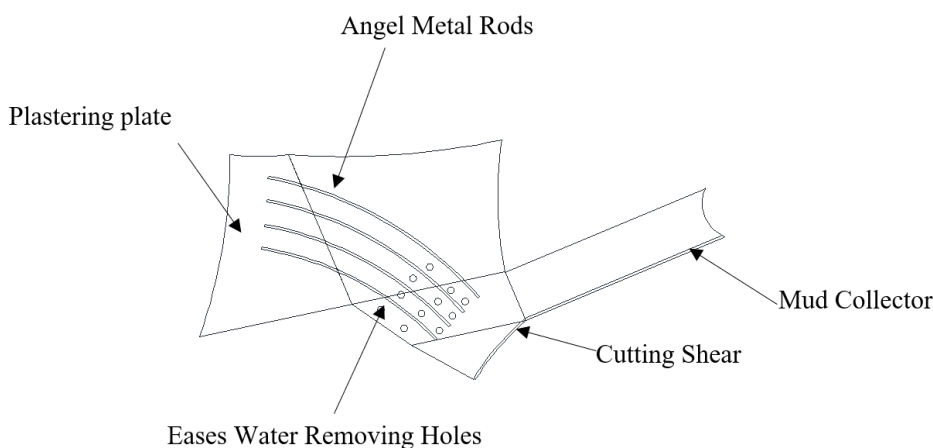
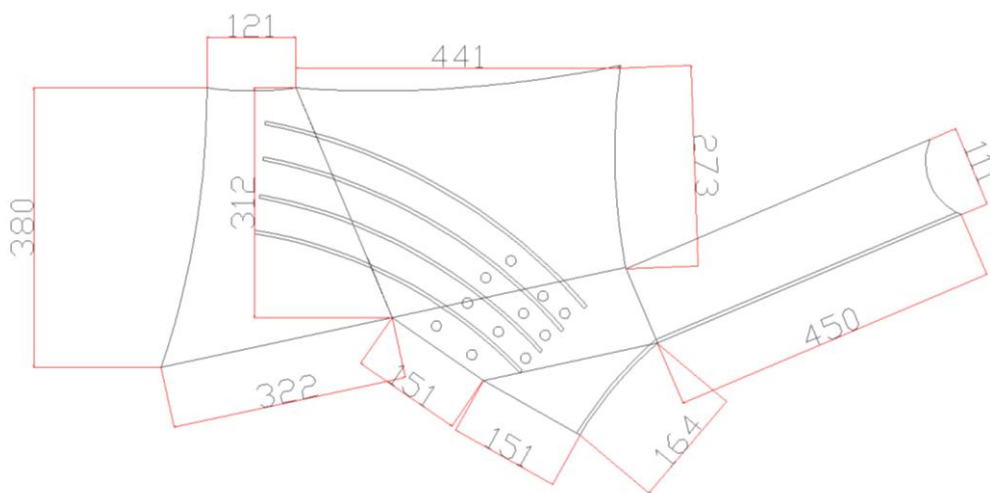

Figure 2: Components of the bund plaster



Drawing 1: Bund Plaster with Dimension

2.5.3 Canal (kiwul-ela) Constructor

Half of galvanize pipe longitudinal direction was used to construct the canal maker. The diameter and length of canal maker were 120 mm and 453 mm respectively. Fig. 3 shows the canal maker with dimensions.

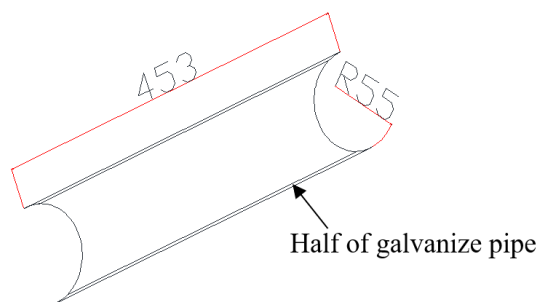

Figure 3: Canal Maker with Dimension

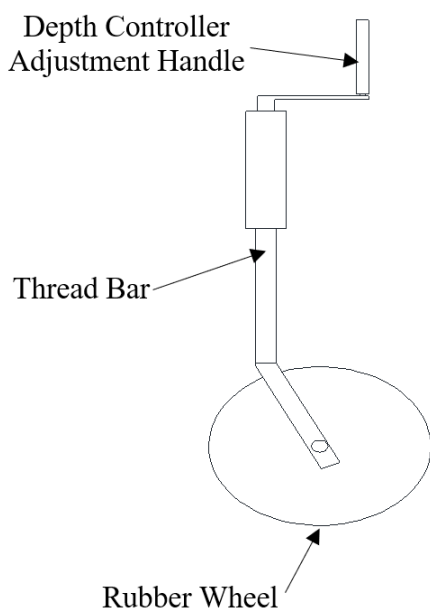
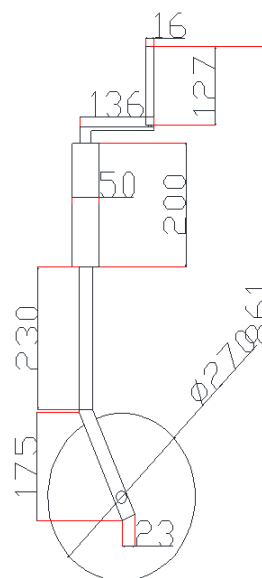

Figure 4: Depth Controller

2.5.4 Depth Controller

The depth controller was used to control the working depth of the bund plaster and to control the amount of mud plastered on the bund. A thread bar ($\varnothing = 25$ mm) maximum and minimum height were 560 mm and 400 mm, respectively. The depth controller was attached to the tail of the frame. Diameter (270 mm) rubber wheel was attached to the bottom of the depth controller to avoid slippage (Drawing 2). Fig. 4 shows the depth controller.



Drawing 2: Depth Controller with Dimensions

2.5.5 Main Frames

The main frame was fabricated using 3 mm gauge 38 mm box bar. The hitch attachment could use to easily move the implement. The height and width of hitch attachment was 95 mm

and 190 mm respectively. The main frame was fixed using three bolts to minimize slipping of the plough. Total length and width of the main frame were 940 mm and 670 mm respectively (Drawing 3). Fig. 5 shows the plough frame.

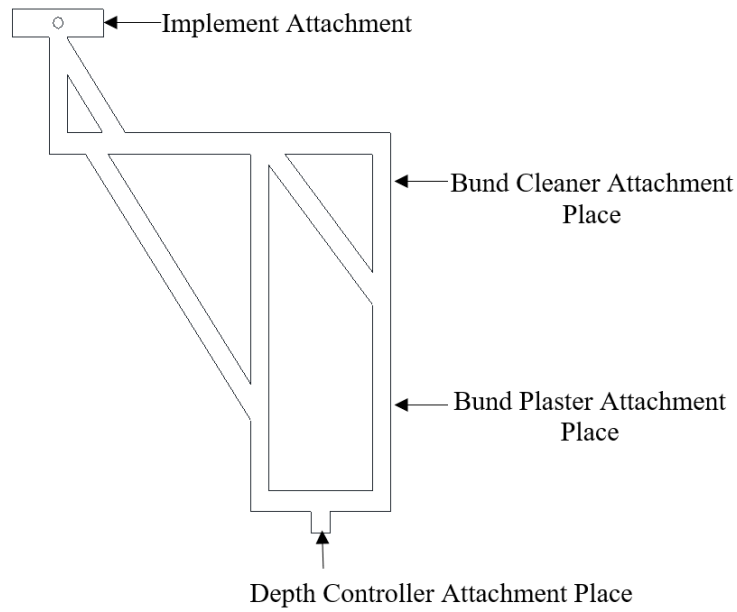
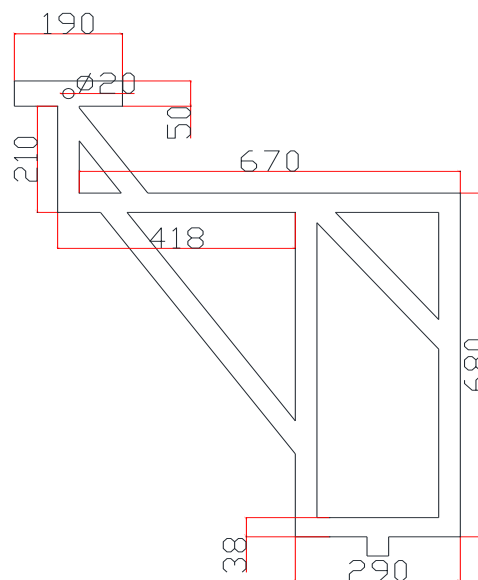

Figure 5: Plough Frame



Drawing 3: Plough Frame with Dimensions

2.5.6 Design Development of the Equipment

Complete 3D drawing of the design is shown in Fig. 6.

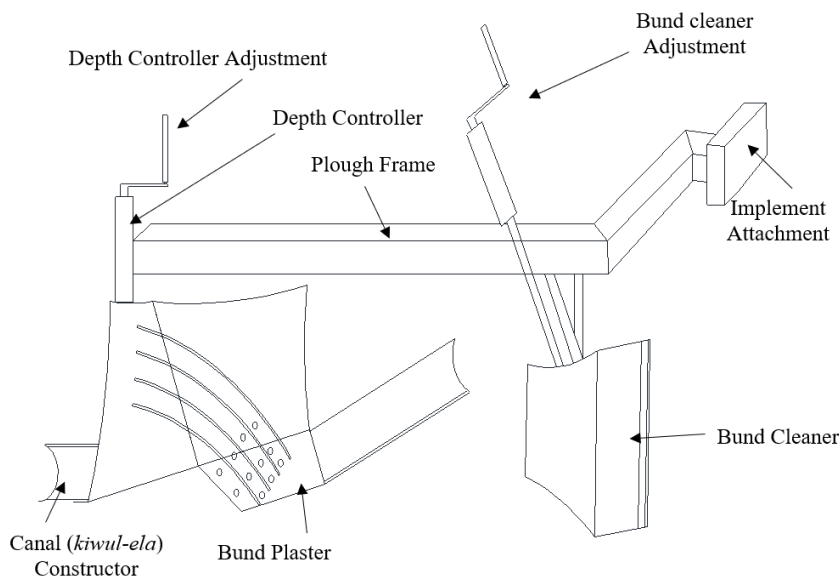

Figure 6: Develop design of the Equipment

2.6 Performance of the Two-wheel Tractor Coupled Bund Plastering and Canal (kiwul-ela) Making Equipment

The bund plastering equipment was tested in the low land paddy field of the farm, Faculty of Agriculture, Rajarata University of Sri Lanka, Puliyankulama, Anuradhapura.

2.6.1 Test Field Conditions

Bulk Density of Soil

Bulk density is the mass of bulk solid that occupies a unit volume of a bed, including the volume of all antiparticle’s voids. A cylindrical core samples of soil were obtained randomly at least three selected locations in the test plot (RNAM, 1983). The bulk density was calculated by equation 1.

$$Bulk\ Density = \frac{M}{V} \dots\dots\dots Eq\ 1$$

$$BD = \frac{4M}{\pi D^2 L}$$

Where; M = Mass contained in core sample of oven dry soil (g)

V = Volume of cylindrical core sample (cm³)

D = Diameter of cylindrical core sample (cm)

L = Length of cylindrical core sample (cm)

Soil Moisture Content

Moisture content (percent) on dry weight basis was estimated by gravimetric method (RNAM, 1983) from randomly selected three different locations of test plot. The moisture content (% dry basis) was calculated by equation 2.

$$Soil\ moisture\ (\%,\ dry\ basis) = \frac{weight\ of\ wet\ soil\ sample - weight\ of\ @oven\ dry\ soil\ sample}{weight\ of\ oven\ dry\ soil\ sample} \times 100 \dots\dots\dots Eq\ 2$$

Economic Analysis

The time required for plastering of 25 m bund by the equipment and the manual method were recorded at five times. The average time for bund plastering by each method was compared (RNAM, 1983).

Comparative Statement of the Equipment and Manual Method

The mechanical method and the manual method were compared to determine the cost and

required time per hectare for bund plastering and *kiwul-ela* construction.

The costs of the mechanical method were considered as cost of fuel, lubrication cost, depreciation cost, and labor cost for operating the machine. In manual method, the labor cost was considered (RNAM, 1983).

The comparison of the time consuming of manual and mechanical methods were calculated by equation 3.

The comparison of the cost of manual and mechanical methods were calculated by equation 4.

$$\text{Save time} = (\text{Time consumption of the manual method} - \text{Time consumption for the mechanical method}) / (\text{Time consumption for the manual method}) \times 100 \dots\dots\dots \text{Eq 3}$$

$$\text{Cost saving from the mechanical method} = (\text{Cost for mechanical method} - \text{Cost for manual method}) / (\text{Cost consumption for manual method}) \times 100 \dots\dots\dots \text{Eq 4}$$

2.7 Performance Criteria

Forward Speed

The speed was calculated from the time required for the tractor to travel the distance (20 m) between the assumed line connecting two poles. Average forward speed was then calculated by the equation 5.

$$\text{Speed} = \frac{\text{Distance}}{\text{Time}} \dots\dots\dots \text{Eq 5}$$

Theoretical field capacity (TFC)

Theoretical field capacity referred to the amount of processing that a machine can accomplish per unit time (Swetnam, 1991).

The TFC was determined by the equation 6.

$$\text{TFC} = \frac{S \times W}{10} \dots\dots\dots \text{Eq 6}$$

TFC = Theoretically field Capacity (hah⁻¹)

S = Traveling Speed (kmh⁻¹)

W = Effective working width (m)

Effective Field Capacity

In the data sheet, time lost for every event such as turning, adjustment, refueling and machine trouble recorded. Time for rectifying machine trouble will vary widely to various factors and its inclusion in time factor sometimes unreasonably lowers the effective field capability. Then effective field capacity of the equipment was determining by the by equation 7 (RNAM, 1983).

$$\text{EFC} = \frac{w_e \times T_p}{w_t \times (T_p + T_l)} \dots\dots\dots \text{Eq 7}$$

W_e = Effective working width (m)

W_t = Theoretical working width (m)

T_l = Time losses (h)

T_p = Productive time (h)

Field Efficiency

This gives an indication of the time lost in the field and the failure to utilize the full working width of the equipment. It is calculated by equation 6 from the test data. (RNAM, 1983). Field Efficiency was calculated by equation 8.

$$FE = \frac{EFC}{TFC} \times 100 \dots\dots\dots \mathbf{Eq\ 8}$$

FE = Field efficiency of the Bund Plaster

EFC = Effective Field Capacity

TFC = Theoretically field Capacity

Fuel Consumption

The following simple method is often used. The tank is filled to full capacity before and after the test. Amount of refueling after the test is the fuel consumption for the test. Then covered area was measured. When filling up the tank, careful attention should be paid to keep the tank horizontal and not to leave empty space in the tank. If this instruction is not observed the data on the fuel consumption would have serious errors. (RNAM, 1983)

Fuel Cost

The fuel cost was calculated by the equation 9 (RNAM, 1983).

Fuel cost = fuel consumption \times average diesel price..... **Eq 9**

Breakeven Point

The breakeven point, the area that a machine has to work per year in order to justify owning the equipment. (RNAM, 1983) Breakeven point was determined by equation 10.

$$Be = \frac{F_c}{V_c - V_{cm}} \dots\dots\dots \mathbf{Eq\ 10}$$

Be = Breakeven point (ha Yr⁻¹)

F_c = Annual fixed cost (Rs Yr⁻¹) (Price of the equipment)

V_c = Variable cost of the manual method (Rs Yr⁻¹)

V_{cm} = Variable cost of the machine (Rs Yr⁻¹) (Rs ha⁻¹) (Fuel cost, Lubrication cost, Operator's wages, Depreciation)

3 Results and Discussion

3.1 The Main Part of the Equipment

The main part of the plastering equipment was bund cleaner, modified moldboard plough, canal (*kiwul-ela*) constructor, depth controller, and main frame.

3.2 Assembling of the Machine

The main components of the equipment were made by flat iron bars and metal sheets. Main frame was fabricated using Iron bar. Bund cleaner and bund plaster were fabricated using metal sheet. Welding was used to permanently fastening the components to the main frame. The bund cleaner was constructed by heavy flat iron. Therefore, the strength of the bund cleaner was high. Bund cleaner was in front of the modified moldboard which perform as bund plaster. Bund cleaner and modified moldboard were also welded in order to increase strength of the equipment. Hitch point and the frame also

welded. The non-adjustable parts of the equipment; depth controller, bund plaster and canal (*kiwul-ela*) maker were welded and adjustable parts; bund cleaner and depth controller were attached by nuts and bolts. The non-permanent fastening method; nuts and bolts help to adjust the plastering height. The non-permanently fastened components could be easily detached for lubrication and transport purposes (Plate 1)



Plate 1 : Bund Plastering and (*kiwul-ela*) Making Equipment

3.3 Specifications of the Equipment

The specifications of the bund plastering and (*kiwul-ela*) making equipment are shown in Table 1.

Table 1: Specifications of the equipment

Component	Dimension
Total length of the equipment	1200 mm
Total width of the equipment	920 mm
Total weight of the equipment	38.85 kg
Length of the hitch point	190 mm
Width of the hitch point	50 mm
Height of the hitch point	95 mm
Maximum height of the depth control wheel	860 mm
Maximum height of the bund cleaner	350 mm
Maximum length of the bund cleaner	340 mm
Maximum height of the modified moldboard plough	380 mm
Maximum length of the modified moldboard plough	550 mm

3.4 Test Field Conditions

3.4.1 Bulk Density of Soil

Results of the bulk density are shown in Table 2. The interpreted result was almost same value. Usually, bulk density of test field Conditions was below the 1.2 g cm⁻³ (Caesar, 2010). Therefore,

this bulk density result was suitable to test field conditions.

Table 2: Bulk density

Sample Number	Bulk Density (g cm ⁻³)
1	1.117
2	1.105
3	1.155
4	1.182
5	1.144
Average	1.1406

The average bulk density of the test field was 1.1406 ± 0.0306 gcm⁻³

3.4.2 Moisture Content

Moisture content results are showing in table 4.3. The highest value of interpreted sample was 16.923%. Therefore, this condition was buildup the water logging condition in area.

Table 3: Moisture content of the soil

Sample	Moisture Content (Dry basis, %)
1	16.923
2	14.118
3	14.250
4	13.728
5	13.736
Average	14.551

Average moisture content dry basis was $14.551 \pm 1.34\%$.

3.5 Economic Analysis

3.5.1 Time Consumption Comparison

Time consumption for the manual and the (use two-wheel tractor) mechanical method was compared.

Time consumption for the manual method was 725 s for 25 m.

Time consumption for the mechanical method was 44 s for 25 m.

$$\text{Saved time} = (725 - 44) / 725 \times 100 = 93.93\%$$

According to the results the mechanical method was effective than manual method.

3.5.2 Cost Comparison

Cost consumption mechanical method was (1500 x 2 Days + 5000 Diesel) = Rs. 8000.00 and cost consumption for manual method was (1500 x 15 Days) = Rs. 22500.00.

$$\text{Cost saving for mechanical method} = (22500 - 8000) / 22500 \times 100 = 64.44\%$$

According to the results the overall idea the equipment was very effective as well as low cost consuming for bund plastering in the rice field.

3.6 Performance Criteria

3.6.1 Speed of the Equipment attached to Two-wheel tractor

The forward speed of two-wheel tractor attached equipment was calculated under different gears.

$$\text{First gear speed} = 1.285 \text{ km h}^{-1}$$

$$\text{Second gear speed} = 2.044 \text{ km h}^{-1}$$

$$\text{Third gear speed} = 3.214 \text{ km h}^{-1}$$

Satisfactory field performances were shown for second gear speed.

3.6.2 Theoretical Field Capacity (TFC)

The plastering height of the equipment was 0.21 ± 0.002 m. The TFCs in different gears were calculated (Table 4). The interpret Sample result highest vale was 67.49×10^{-3} ha h⁻¹. But satisfactory field performances were shown for second gear theoretical field capacity.

Table 4 Theoretical field capacity

Tractor Gear	TFC
First gear	$26.98 \times 10^{-3} \text{ ha h}^{-1}$
Second gear	$42.92 \times 10^{-3} \text{ ha h}^{-1}$
Third gear	$67.49 \times 10^{-3} \text{ ha h}^{-1}$

3.6.3 Effective Field Capacity (EFC)

The effective field capacity of the equipment for one-hectare in different gear speeds were calculated (Table 5). Result showed that approximately same value for all gears.

Table 5 Effective field capacity

Tractor Gear	EFC
First gear	14.59 ha h ⁻¹
Second gear	14.59 ha h ⁻¹
Third gear	14.59 ha h ⁻¹

3.6.4 Field Efficiency

The field efficiency of the equipment for one hectare under different gear speeds were calculated. The interpret sample result highest vale was 54.07%. But satisfactory field performances were shown for second gear field efficiency (Table 6).

Table 6 Field Efficiency (FE)

Tractor Gear	FE
First gear	54.07%
Second gear	33.94 %
Third gear	21.61%

3.6.5 Fuel Consumption

The fuel consumption for using the equipment with Kubota K-75 tractor for 1ha was 37 l.

Therefore, fuel consumption and fuel cost were 37 lha⁻¹ and Rs. 4844.00 ha⁻¹ (37 l × Rs 132.00), respectively.

3.6.6 Breakeven Point

Assuming the price of the equipment, variable cost of manual method and summation of fuel cost, lubrication cost, operator's wages, depreciation (variable cost) were Rs. 60,000.00, Rs. 10,000.00. and Rs. 15000.00, respectively.

$$\begin{aligned} Be &= 60,000 / (10,000 \times 15000) \\ &= 0.0004 \text{ ha. Yr}^{-1} \end{aligned}$$

This indicated that this equipment is appropriate for small scale rice farmer.

4 CONCLUSION

4.1 Conclusion

The main components of the equipment were bund plaster, bund cleaner, *kiwul-ela* maker, depth controller, and main frame. The field performance of the equipment was measured, and the average speed was $2.044 \text{ kmh}^{-1} \pm 0.97$ (second gear), the average theoretically field capacity was $42.92 \times 10^{-3} \text{ ha h}^{-1}$ and the field efficiency was 33.61%. In comparison with the manual method, this equipment could save 93.93% of time and 64.44% of cost for plastering the bund per hectare of rice field. Therefore, it can be concluded that the two-wheel tractor coupled bund plastering and canal (*kiwul-ela*) making equipment is more effective and more efficient than the bund cleaning, bund plastering and *kiwul-ela* making, by manual method. According to the results, the developed equipment could be suggested for the small-scale paddy farmers.

4.2 Suggestions and Recommendations

Used material strength is somewhat low hence; higher strength materials such as 2'x2' box iron bars could be recommended to increase the strength of the attachment.

The plastering height could be further increased by modifying the moldboard of this equipment. The plastering width and thickness can be optimized by modifying the plastering plate.

5 References

- Caesar J (2010) How to prepare the rice field Land. (5th ed) open academy of India. Available at: [http://www.philrice.gov.ph.18, 3: 274-296](http://www.philrice.gov.ph.18,3:274-296) .
- DCS (1991) Department of Census and Statistics. Statistical Abstract of the Democratic Socialist Republic of Sri Lanka, Colombo.
- DOA (2010) Department of Agriculture, Sri Lanka, Rice Book Sri Lanka, 55
- DOA (2015) Department of Agriculture, Sri Lanka, Rice Book Sri Lanka, 55
- DOA (2018) Department of Agriculture, Sri Lanka, Rice Book, Sri Lanka, 455
- DOAI (2015) Department of Agriculture India "Directory of Agriculture Machinery and Manufacturers", Retrieved on October 15, 2018, from <http://www.worldbank.org>.
- RNAM (Economic and soil commission for Asia and Pasific Regional Network for Agiculture Machinery (1983) RNAM Test Codes and Procedures for from Machinery, Technical Series No 12, Economic and soil Commission for Asia and Pacific Resional Network for Agriculture Machinery.
- Seleshi, B A, Philippe L, Taffa, T (2009) Irrigation methods: Surface Irrigation-Options for small holder, international program for technology and research in irrigation and drainage. Retrieved March 02, 2019. 78(7) :65-125-
projects.worldbank.org/P009965/punjab-irrigation-drainage-project?lang=en.
- Swetnam L D (1991) Farm Machinery, *Agricultural Engineering Extension Publications University, Calculating farm Machinery Field Capacities*, 6. Available at: <http://uknowledge.uky.edu/aen-reports>.
- Thilakaratna, H M, Thilakaratna, I G (2015) Department of Agriculture, India. "Directory of Agriculture Machinery and Manufacturers" Available at <http://web.worldbank.org>. [Accessed December 7, 2018].
- Vaidya B (2016) fabrication of soil pulverizes and bed re-maker, International Journal of Innovative Research in Science and Engineering, 2(04) 225-230. Available at: <http://www.ijirse.com>.

Annexure



Bund Plaster with Frame



Angel Metal Rods



Bund Cleaner



Bund Plaster and Bund Cleaner



Fabricated Equipment