

RESEARCH ARTICLE

Design and Development of a Two Wheel Tractor Driven Coconut Fertilizer Applicator

A.J.Fernando^{1,3}, T.B. Adhikarinayake² and G.V.T.V.Weerasooriya¹

¹Department of Agricultural Systems, Faculty of Agriculture, Rajarata University of Sri Lanka, Puliyankulama, Anuradhapura.

²Agriculture and Post Harvest Technology Engineering Division, National Engineering Research and Development Centre, Ekala, Ja-Ela.

³Corresponding author:jayaruwanifernando@yahoo.com

ABSTRACT

Coconut (*Cocos nucifera* L.) is a perennial tree crop with about 60 years of economic life span. Decreasing soil fertility over several decades due to inadequate replenishment of the exhausted nutrients is a major problem affecting coconut production. The annual yield from a single tree can be increased from 50-70 nuts up to 100-125 nuts by proper application of fertilizer. There is no efficient method to apply fertilizer to coconut estates at present except manual application, which is laborious. The general objective of this research was to investigate an efficient method for applying fertilizer to coconut estates.

After investigating physical properties of raw materials and their influences on the performance of fertilizer application, a two-wheel tractor driven granular fertilizer applicator was developed. Main components of the applicator are hopper, opposite-direction screw, two sets of furrow openers, fertilizer tubes, and a furrow closer. Power transmission from the engine to the applicator was done by chain and sprockets. The applicator was designed to apply 5 kg of fertilizer mixture per palm at an optimum speed of 1.1 km/h.

The fertilizer applicator was evaluated in a coconut estate and received satisfactory results. It performed at a fertilizer feeding capacity of 0.45 ha/hr with 72.7 % efficiency. Compared to the traditional method, this fertilizer applicator could save 96.5 % of time and 94 % of the cost of fertilizer application per hectare.

Key words: Coconut cultivation, Fertilizer applicator, Coconut fertilizer

INTRODUCTION

On average a coconut tree bears 50-70 nuts per year. With fertilizer, productivity can

be increased up to 100-125 nuts per year ('Govibima'26/04/2004). In recent years, there has been a drastic reduction in fertilizer application in the coconut sector. Although

the government provides fertilizers at a subsidized price, the landlords are not motivated to apply fertilizer due to lack of labour and efficient methods of applying fertilizer. Currently fertilizer is applied manually, which is time consuming and contributes to the high cost of production. Uniformity of fertilizer distribution around the palm cannot be achieved manually. Furthermore, the amount of fertilizer applied to a palm could vary due to incorrect measurements. Unfortunately a suitable machine is not available for the application of fertilizer to coconut cultivations.

The general objective of this research was to increase the coconut productivity in Sri Lanka by introducing an efficient method of applying fertilizer to coconut estates. The specific objectives were; to design and develop a fertilizer applicator operated by a two wheel tractor, to study the performance of the fertilizer applicator, and to increase the coconut production in Sri-Lanka at a reduced cost by increasing efficiency. Thus it will increase the coconut production in Sri-Lanka at a reduced cost by increasing efficiency.

METHODS AND PROCEDURES

It is necessary to study the behaviour of the fertilizer mixture in order to develop the required components of the fertilizer applicator. A dry mixture of urea, Murate of potash, Eppawala rock phosphate, and dolomite in the proportion of 1:2:1:1 was used to test the applicator. The angle of friction, angle of repose, bulk density, and flowability of the fertilizer mixture were determined.

The flowability was measured by measuring the discharge of fertilizer within a

10 s period at different speeds of the driving shaft. The rotational speed of the screw shaft was measured using a tachometer.

Design and Development of the Fertilizer Applicator

The granular type of fertilizer mixture was selected because it requires simple infrastructure and does not require dilution. The size and topography of coconut estates match the capacity of two wheel tractors. Thus, the model EMI 7 two wheel tractor with 7 hp (5kW) rating was used as the power source.

The design should be facilitated to open furrows, direct the contained fertilizer to the opened furrows by a metering mechanism and finally close the furrows. Thus the unit operations of containing fertilizer, metering mechanism, applying fertilizer, opening of furrows, and closing furrows should be performed by the fertilizer applicator.

Furrow Opener

The furrow opener must be constructed to suit the field conditions of coconut lands. Two furrow openers were constructed using mild steel to cut the soil and the roots to open furrows. The mould board plough, two-way trailing plough, and ridger were used as an inspiration for the construction of the furrow openers.

The shares of furrow openers were designed to dig into the soil and separate the surface soil from the bed soil. Side wings helped to partially turn the soil to make a furrow. Two furrow openers were vertically attached to the front frame of the fertilizer applicator. The distance between two furrow

openers were 30 cm. The depth of the furrow between 8 - 15 cm, can be controlled by shifting the furrow openers.

Hopper

The hopper was constructed to contain fertilizer before it was applied to the soil. The following factors were considered when designing the hopper geometry.

A symmetric shape hopper was constructed to overcome the segregation problems. Forty five degree steep and smooth hopper walls were constructed to obtain the ideal mass flow pattern (Arnold et al., 1981). Mild steel was selected as the construction material due to its low cost.

The lower part of the hopper was constructed in a wedge shape for its capability of handling materials with a wider range of flowability (Marinelli & Carson, 2001). The construction of a screw conveyor at the bottom of the hopper was also aided by this wedge shape. The upper part of the hopper was constructed in a pyramid shape to obtain a larger storage capacity (Chase, 2008).

Maximum load weight of 25 kg can be handled by 95 % of men and 70 % of women (ISO 11228-1). A person can make the coconut fertilizer mixture of 25 kg and load it at once into the hopper. Thus the capacity of the hopper was designed to apply fertilizer to five palms per load.

Screw Conveyor

The mild steel horizontal screw conveyor on the bottom of the hopper was used as the

metering mechanism. Fertilizer was equally transferred to both sides and discharged to the two fertilizer tubes at the same rate. This was achieved by attaching two coiled spiral blades in opposite directions from the center of the same shaft in a U-shaped trough. The shaft is driven at one end and free at the other. The discharge points were at the base of the trough.

The rotational rate of the shaft helped control the rate of volume transfer by the screw conveyor. Thus the volume of fertilizer applied for each palm could be controlled. The screw conveyor shaft was powered by the power take-off shaft of the tractor. The PTO driven screw conveyor shaft was supported by bearings that revolved in the trough. The constructed metal pinned shaft helped break the arch of fertilizer that occurred over the screw conveyor.

The metal pinned shaft consisted of 12 pins that were spirally attached to the shaft. It was powered by the transmitted power from the chain and sprocket attached to the screw conveyor shaft. The two sprockets had 13 teeth and rotated at the same speed. The clutch for the metering mechanism was a flap that was placed on the top of the fertilizer tubes.

Fertilizer Tubes

The fertilizer tubes were constructed to carry fertilizer from the fertilizer metering mechanism to the opened furrows in the soil. The construction material was transparent plastic, so the operator could see whether fertilizer was being applied or not.

Furrow Closer

The furrow closer was used to cover the applied fertilizer with soil. The rectangular part helped to collect the soil and the V-shaped part helped to move the soil to the two furrows. Mild steel was used as the construction material.

Power Transmission

Chain and sprockets were used to control the mechanical power gained by the engine of the two wheel tractor and to get the required rate of power for the rotation of the shaft in the screw conveyor. This helped to feed the correct amount of fertilizer per palm.

Selection of Set of Sprocket System

An experiment was carried out to determine the suitable chain and sprockets system for the fertilizer applicator to spread the fertilizer in required quantities around the coconut tree. Five kilograms of the fertilizer mixture was applied to the hopper, each time

with a different sprocket system. The fertilizer applicator was operated around the palm within a 1524 mm radius circle. The rotational speed of the Power Take off (PTO) shaft of the two wheel tractor was kept constant at 118 rpm. The actual length travelled by the tractor to apply 5kg of the fertilizer mixture with each sprocket system was measured.

Fabrication and Assembling of Components

The fertilizer applicator was attached to the rear of the two wheel tractor. The two furrow openers were attached to the front of the frame. The two fertilizer application tubes were attached to the back of furrow openers. The furrow closer was attached to the back of the frame. The hopper was attached to the top of the tractor closer to the rear. This helped to properly balance the tractor movement and provided sufficient space for the hopper.



Figure 1 Fabricated fertilizer applicator

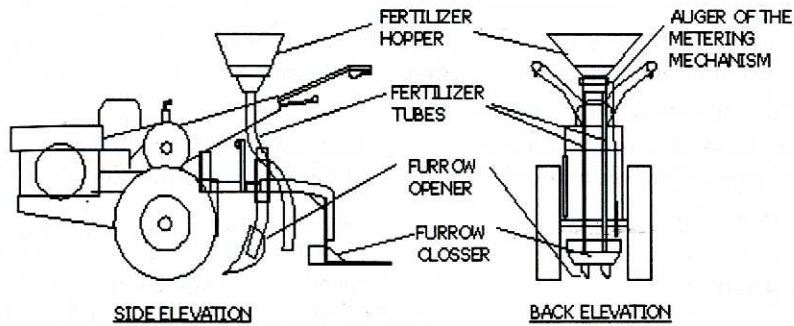

Figure 2 Isometric side and back elevation of the fertilizer applicator

Performance of the Fertilizer Applicator

The fertilizer applicator was tested in a coconut estate with triangular planting pattern (8 m x 8 m x 8 m). Figure 3 indicates the travelling pattern of the two wheel tractor in the coconut estate.

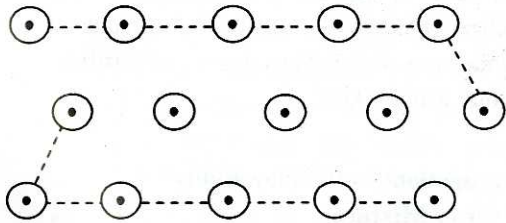

Figure 3: The travelling pattern of the two wheel tractor

The main field operation aspects according to the RNAM (1983) test codes were; work capacity (theoretical and actual), field efficiency, and fuel consumption per hour. An experiment was also carried to find the fertilizer application efficiency in the field.

Actual Work Capacity: Actual work capacity is the actual area covered per unit time.

NOTE: "Time" in this context pertains to the actual time which includes time for moving

from one tree to another, and loading of fertilizer.

Ten neighbouring coconut palms were selected. Fertilizer application was carried out and the total time required for the operation was measured. Using this, the time required to fertilize one hectare was calculated.

Theoretical Work Capacity: Theoretical work capacity is the computed area covered per unit of time.

Field Efficiency: Field efficiency is the ratio of actual work capacity to the theoretical work capacity

Fuel consumption: Fuel consumption rate is the volume of fuel consumed by the engine.

The tank was filled with diesel to its full capacity before and after each test trial. It was filled while horizontal, not leaving any empty space in the tank. The volume of fuel refilled after applying fertilizer to ten coconut palms was the fuel consumed during the test. Using this, the fuel required for one hour was calculated.

Fertilizer Application Efficiency: The selected sprockets of 30 teeth (for the screw

conveyor shaft) and 36 teeth (for PTO shaft) were used in testing the fertilizer application efficiency in the field. The tractor was operated at different speeds and the time required to apply 5 kg of fertilizer mixture per palm was measured.

Economic Analysis

Traditional Method of Fertilizer Application

A one foot wide furrow up to 10 cm depth is cut manually with a mamoty around the coconut palm, five feet away from the base of the palm. Then the fertilizer mixture is applied manually and the furrow is closed manually using a mamoty. Figure 4 indicates the traditional method of fertilizer application.



Figure 4: Traditional method of fertilizer application

Time Consumption

Five palms were selected and fertilizer was applied to each palm using the manual and suggested fertilizer applicator methods. The time consumed in each trial was

determined and the collected data was analyzed using a pooled t-test.

Comparative Statement of Cost and Time of Fertilizer Application

Time and cost required for fertilizing was found for ten coconut palms near each other by the fertilizer applicator method and for five palms by the traditional method.

RESULTS AND DISCUSSION

In order to develop the components of the fertilizer applicator, properties of the fertilizer mixture were investigated. The angle of repose of the fertilizer mixture was 45° . The angle of friction of the fertilizer mixture with mild steel sheet was 55° and with stainless steel sheet it was 35° . The weight of the fertilizer mixture in a 500 ml graduated cylinder was 452 g. Thus density of fertilizer mixture was 0.9 kg/l.

Investigation of Flowability of the Fertilizer Mixture

The coconut fertilizer mixture flowed smoothly through the screw conveyor without clogging. Figure 5 shows the flowability of the fertilizer mixture through the screw conveyor at different revolution of the screw shaft. It has a linear variation of discharge rate.

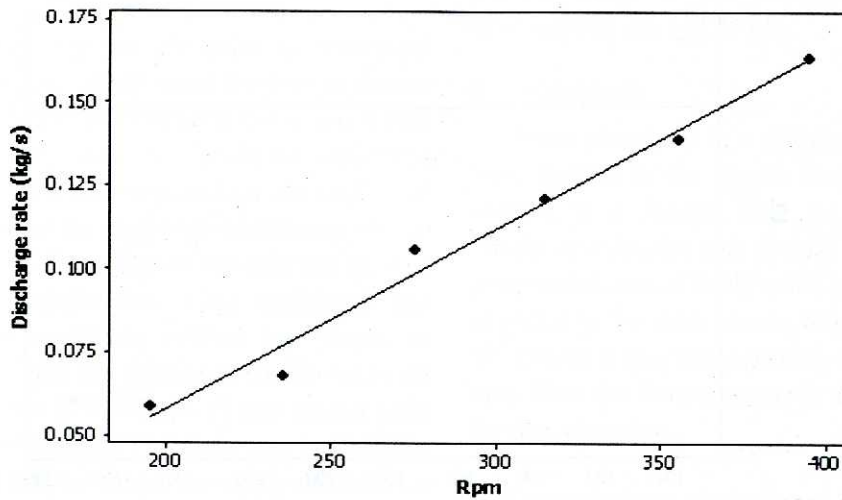

Figure 5 Variation of discharge rate with different rotational speeds

Selection of Set of Sprocket System

Figure 6 shows variation of I/L with different rotational speeds of the screw shaft. The upper sprocket attached to screw conveyor shaft and the lower sprocket attached to PTO shaft. Sequentially the number of teeth in each sprocket were changed as; (1)15, 30; (2)15, 36; (3)30, 36; (4)36, 30

Theoretically $I/L=1$ should be achieved by the fertilizer applicator. This was achieved by a 30 teeth sprocket for A and a 36 teeth sprocket for B.

Performance of the Fertilizer Applicator

The screw conveyor, furrow openers, furrow closer, and fertilizer tubes performed

furrows, the fertilizer was applied to the furrows by the fertilizer tubes, and then furrow closing board closed the furrows immediately

Actual work capacity of the fertilizer applicator was 0.45 ha/h on the basis of 183 coconut palms/ha. The theoretical work capacity was 0.62 ha/h. Thus the field efficiency was 72.72 %. The fuel consumption rate of fertilizer applicator was 0.75 l/h.

Fertilizer Application Efficiency

Figure 7 shows an initial linear variation and finally constant rate of the fertilizer application as a function of the tractor speed. The optimum fertilizer application rate was 0.156 kg/s. The screw shaft rpm was 204.

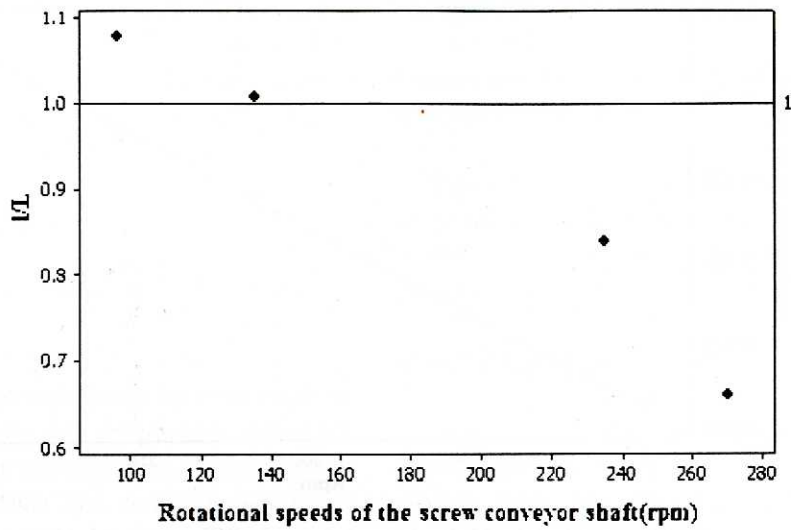

l: Actual length travelled by the tractor when the hopper was emptied (m), *L*: Theoretical length of manure circle (9.57m)

Figure 6 Variation of actual length over theoretical length (l/L) with different rotational speeds of screw shaft

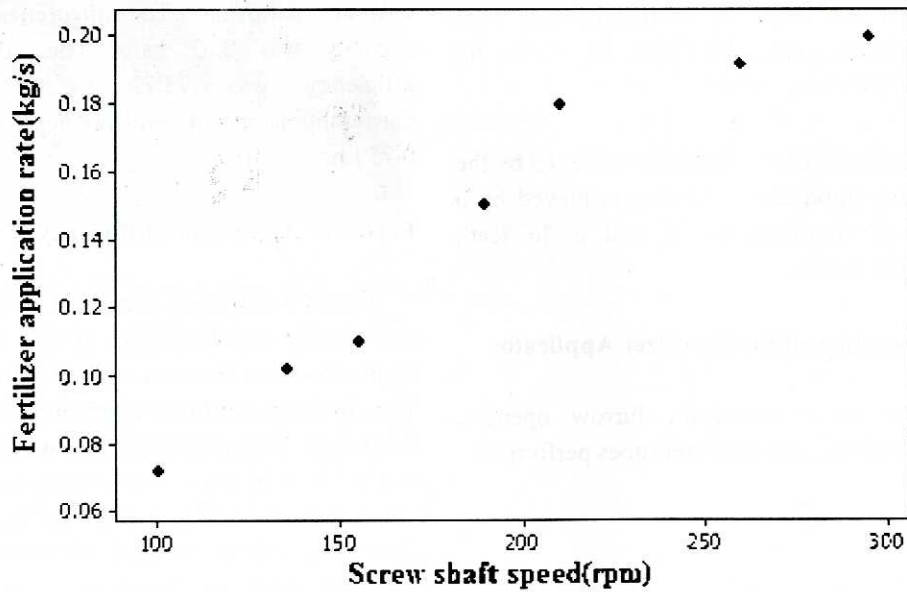

Figure 7 Fertilizer application rate vs. screw shaft speed

Time Consumption

The time required per palm by traditional method was 974 ± 29 s and fertilizer applicator method was 32 ± 3 s. The P-Value was 0.000. Thus there was a significant difference between the time required for the traditional method and the suggested fertilizer applicator method. Comparison of the cost and time of fertilizer application using traditional and fertilizer applicator method has shown in table 1. This has calculated on the basis of; diesel price is Rs.78.00/= (Local market price on 1st of May 2011), labour cost is Rs.700/= per worker, one labour can apply fertilizer for 17 palms per day, labour cost is Rs. 60/= per palm for manual fertilizing, one labour works 6 hrs per day, optimum planting density of

coconut estate is 183 palms/ha, and fuel consumption rate is 0.75 l/hr.

Force Analysis

When ploughing in a straight line, forces were applied to the wheels and the furrow openers in a straight line. As the tractor travels in a circular path around the tree, the inner wheels travel freely while all traction is provided by the outer wheels. Side reaction 'R' created a drag force making it difficult to turn. Thus the furrow opener is angled at 14° for easy operation.

Figure 8 shows the balanced forces while the fertilizer applicator is in operation. Due to this modification it was easier for the operator to turn the machine around the palm.

Table 1: Comparison of the Cost and Time of Fertilizer Application using Traditional and Fertilizer applicator method

Method	Cost of fertilizing per ha(Rs)	Time for fertilizing per ha(hr)
Traditional	10,980.00	64.58
Fertilizer applicator	^a 653.71	2.24

^a Include the labour cost of Rs.522.67 and fuel cost of Rs.131.04

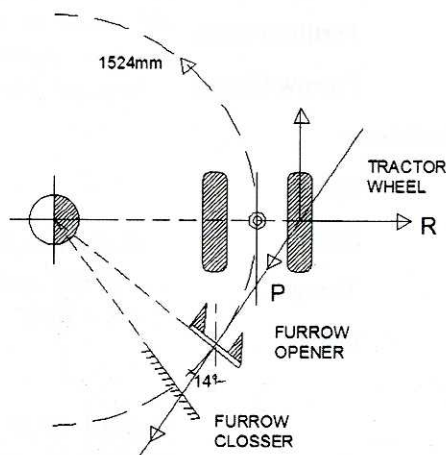

Figure 8 Balanced forces

Table 2: Specifications

Particulars		Dimensions
Overall dimensions in cm without tractor:	Length:	336
	Width:	92
	Height:	190.8
Overall dimensions in cm with tractor:	Length:	166.8
	Width:	75.6
	Height:	186.5
Overall weight without fertilizer:		42 kg 500 g
Hopper capacity:		46,706.6 cm ³
Particulars		Dimensions
Recommended travelling speed:		1.1 km/h
Recommended PTO revolution speed:		204 rpm
Speed ratio of metering shaft to input shaft:		1:1.2
Fuel consumption rate:		0.75 l/h
Field efficiency:		72.72 %
Thickness in mm:	Hopper:	0.9
	Shares:	6.5
	Wings:	3
	Fertilizer tube:	3
	Furrow Closer:	0.9
The average depth of the furrow:		10.16 cm
Diameter in mm:	Shaft:	20.0
	Screw:	25.4
	Trough:	63.5
	Outlet:	50.8
Screw conveyor length:		305 mm
Pitch:		25.4 mm

CONCLUSIONS

A well constructed machine was designed and developed to apply fertilizer to coconut palms. In comparison with the traditional method, this fertilizer applicator could save 96.5 % of time and 94 % of the cost of fertilizer application per hectare of coconut plantation. The fertilizer applicator was evaluated in a coconut land and received satisfactory results. It performed at a fertilizer feeding capacity of 0.45 ha/hr with 72.7 % efficiency. The fuel consumption rate was 0.75 l/h. This coconut fertilizer applicator has the potential of becoming a powerful tool in the field for the application of inorganic fertilizers.

ACKNOWLEDGEMENT

My sincere gratitude offers to Dr. Eng. (Mr.) T.B. Adhikarinayake, and Mr. G.V.T.V. Weerasooriya for supervising the project. Honest thanks are extended to Eng. D.R. Pullaperuma, the Chairman of NERDC of Sri Lanka for providing required funds and facilities. Also, I would like to thank Mr. W.K.R. Peiris, research officer and all technical staff members of APHT, NERDC.

REFERENCES

- Arnold P.C., McLean A.G. & Roberts A.W. (1981). Bulk solids handling. The Design of Storage Bins for Bulk Solids Handling, 1(1).
- Bandara H.R.U.D. (2004). Main Reasons Affect for the Reduction of Coconut Production. 'Govibima' Lankadeepa news paper, 26 April.

International Standard Organization. (2003). Ergonomics – Manual Handling. Part 1: Lifting and carrying. ISO 11228-1.

Regional Network for Agricultural Machinery. (1983). RNAM Test Codes & Procedures for Farm Machinery Issue 12 of Technical series. Bangkok UN industrial development organization: Economic and Social Commission for Asia and Pacific Regional Network for Agricultural Machinery.

www.inti.gob.ar/cirsoc/pdf/silos/SolidsNotes10HopperDesign.pdf. Accessed in May 2011.

www.jenike.com/Articulos/solve-solids-flow-probs.pdf. Accessed in April 2011